



## Service Info



# Graded rolling contact rocker arms

## for BMW Valvetronic and PSA engines

Manufacturers: BMW, Citroën, Mini, Peugeot

Part no./OE-numbers:

INA	BMW	PSA
422 0221 10	11 33 7 559 792	0903.H3
422 0222 10	11 33 7 559 793	0903.H5
422 0223 10	11 33 7 559 794	0903.H6
422 0224 10	11 33 7 559 795	0903.H7
422 0225 10	11 33 7 559 796	0903.H8
422 0226 10	11 33 7 559 797	0903.J6
422 0231 10	11 33 7 530 979	-
422 0232 10	11 33 7 530 980	-
422 0233 10	11 33 7 530 981	-
422 0234 10	11 33 7 530 982	-



Image 1: Overview of the BMW Valvetronic

In BMW Valvetronic and PSA engines, graded rocker arms are fitted on both the intake valve side and exhaust valve side.

The rocker arms are each marked with a code number (see Image 2), with one exception. In this differing design, no code number is provided on the rocker arm.

The rocker arm must always be replaced with a part of the same type. This means that all of the rocker arms fitted in the engine must have the same grading. In other words, all rocker arms must either have the same code number or none at all.

On rare occasions, it may be the case that rocker arms of different gradings are fitted. In this case, the rocker arm to be installed must have the same grading as the one removed from the system.

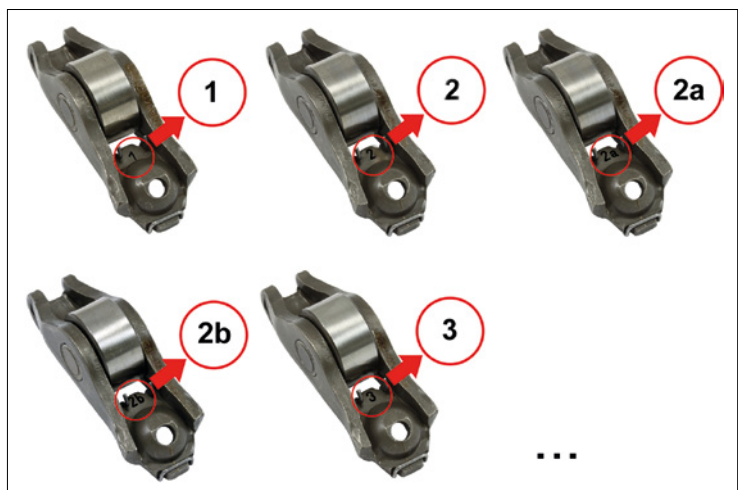

Image 2: Example of markings on certain rolling contact rocker arms

### Technical background for Valvetronic engines (Image 3):

In this case the intake valve assumes the functions of the throttle valve and is not driven directly by the camshaft (1) but via an intermediate arm (2).

The intermediate arm (2), which is also classified, contains a rolling element in the centre on which the cams run. The lower end sits on the rolling element of the rocker arm (3) with hydraulic compensating element (7).

At the top, the arm (2) is connected to an eccentric shaft (4) via a second rolling element. An electric motor (5) rotates the eccentric shaft (4) according to the driver's required load status. The intermediate arm (2) transfers the rotation of the cams to the valve (6), depending on the position of the eccentric element. Variable adjustment of the system is carried out on the basis of the engine speed and the position of the accelerator.

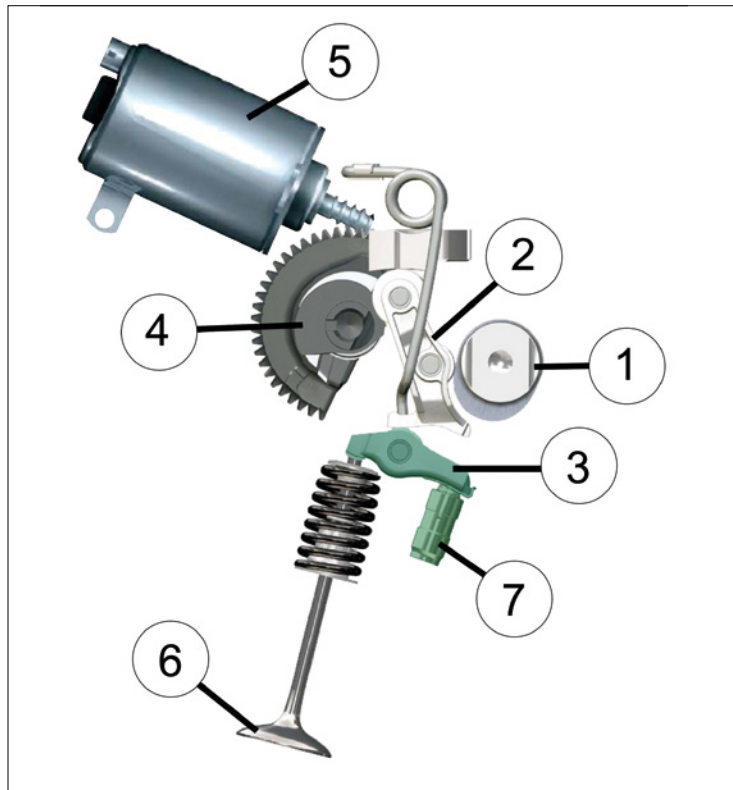

Image 3: Detailed view of the system components in a BMW Valvetronic

Observe the specifications of the vehicle manufacturer!

Spare parts and technical information can be found under [www.schaeffler-aftermarket.com](http://www.schaeffler-aftermarket.com) or [www.RepXpert.com](http://www.RepXpert.com).